

PETRI
REPAIR MANUAL
7S

PETRI CAMERA COMPANY, INC.

CONTENTS

SECTION I	: TROUBLE AND REPAIR	1
	WINDING	1
	REWINDING	1
	SHUTTER	1
	DIAPHRAGM	3
	SELFTIMER	3
	SYNCHRONIZATION	3
	METER	4
	COUNTER	4
	RANGE-FINDER	5
SECTION II	: ADJUSTMENT	6
	1. Adjustment of Amount of Winding and Wind gear pawl (70)	6
	1-1. Adjustment of Wind gear pawl	
	1-2. Adjustment of Amount of Winding	
	1-3. Checking of Stopper Position	
	1-4. Adjustment of Surplus amount of Winding of Cocking lever (226)	
	1-5. Adjustment of Shutter set bar (78)	
	2. Adjustment of Slow speed escapement (207)	7
	3. Adjustment of Selftimer gear (180)	7
	4. Adjustment of Shutter speed	8
	5. Adjustment of MX delay action gear (185) and MX fly wheel (184) ..	8
	6. Adjustment of Synchronization contact	8
	6-1. Adjustment of X contact	
	6-2. Adjustment of M contact	
	7. Adjustment of Counter	9
	8. Adjustment of Range-finder	9
SECTION III	: FINAL INSPECTION	11
ATTACHMENT	: TABLE OF PARTICULAR TOOLS	13

SECTION I : TROUBLE AND REPAIR

TROUBLE	CAUSE	REPAIR
<u>WINDING</u>		
Impossible to wind	<ol style="list-style-type: none"> 1. Stopper (74) is deformed. 2. Stopper (74) does not work well. 3. Shutter set bar (78) does not work well. 4. Stopper spring (79) is off. 5. Shutter set bar (78) is bent. 6. Wind gear pawl (70) is out of place. 7. Shutter set bar (78) and Shutter set ring (132) are deformed because of the shutter being broken. 	<p>Replace it.</p> <p>Referring to 1-3 of SECTION II, adjust it.</p> <p>Referring to 1-5 of SECTION II, adjust it.</p> <p>Correct the figure so that it may not come off.</p> <p>Adjust the bend or replace it.</p> <p>Referring to 1-1 of SECTION II, adjust the position right.</p> <p>Refer to SHUTTER "Shutter cannot be set" of SECTION I.</p>
Wind lever does not return smoothly.	<ol style="list-style-type: none"> 1. Wind lever (57) is bent, hitting Slot cover base (52) or Body (110). 2. Lever return spring (55) is off. 	<p>Adjust the bend or replace it.</p> <p>Adjust the tip of Lever return spring and fix it right.</p>
Shutter cannot be released unless Wind lever is wound twice.	<ol style="list-style-type: none"> 1. Drive pin screw (54) is loose. 	<p>Referring to 1-2 of SECTION II, tighten it.</p>
Wind lever can be wound twice.	<ol style="list-style-type: none"> 1. Stopper spring (79) is off. 2. Stopper (74) does not work well. 	<p>Adjust the tip of Stopper spring.</p> <ol style="list-style-type: none"> i. If Stopper is deformed, replace it. ii. If Stopper hits Body (110), scrape the side of Stopper.
Film cannot be transported.	<ol style="list-style-type: none"> 1. Sprockets (41) race. 	<ol style="list-style-type: none"> i. Take out Drive shaft (44) and clean it. ii. When Rewind button does not work well, take it out and ream the hole of Bottom cover (2).
<u>REWINDING</u>		
Heavy in rewinding film	<ol style="list-style-type: none"> 1. Rewind knob (3) does not work smoothly. 	<ol style="list-style-type: none"> i. Take out Rewind knob and put glove oil on Rewind shaft (50) and Spool bearing (48).
<u>SHUTTER</u>		
Shutter cannot be set.	<ol style="list-style-type: none"> 1. Shutter set bar (78) and Shutter set ring (132) are bent. 	<p>Adjust the bend or replace them.</p> <p>Note: The trouble is mainly due to the defect of shutter; as Cocking & drive lever (206) is inoperative, winding is done forcibly, resulting in the bend, so check the shutter.</p>

TROUBLE	CAUSE	REPAIR
Shutter cannot be released.	2. Cocking lever (226) is slipped out of place because of looseness of Cocking lever screw (225).	Get rid of looseness between Cocking & drive lever (206) and Cocking lever, and tighten Cocking lever. Use locking paint (synthetic resin).
	3. Shutter release ring (130) does not work properly, so that it continues pushing Release bar (194).	Smooth the surface of Shutter release ring or replace it.
	4. Release arm does not work smoothly so that Shutter button does not return.	Adjust it.
	5. Release bar (194) does not return smoothly.	Clean it.
	6. Drive ring stopper (183) does not work smoothly.	Adjust the parallel between Drive ring stopper and Gear base (182) so that Drive ring stopper may work smoothly.
	7. Spring of Cocking & drive lever (206) is off.	Adjust the figure of the spring or replace it.
	8. Drive ring stopper (183) wears out, so that Shutter drive ring (220) cannot hook.	Replace Drive ring stopper.
	1. Mechanism of MX fly wheel (184), MX delay action gear (185) and Sector gear (189) does not work well.	Referring to 5 of SECTION II, take out each gear, wash, and put glove oil on.
	2. Biting of MX fly wheel (184), MX delay action gear (185) and Sector gear (189) is not good.	Referring to 5 of SECTION II, adjust the bend of each axis of Gear base (182) or replace it.
	3. The sliding part of Drive ring stopper (183) and Shutter drive ring (220) does not move well.	Polish the part with oil stone. Put MOS2 grease on it.
	4. MX switch lever working wrong, M contact (199) hits MX delay action gear (185), so that mechanism of MX fly wheel (184), MX delay action gear and Sector gear (189) does not work.	Adjust the figure of MX switch ring spring (213).
	5. Selftimer gear stops halfway, so that Shutter drive ring (220) does not work.	Wash Selftimer gear with mixed abluent (benzine=10 and glove oil=1). Do not put oil on the axis.
	6. Slow speed escapement (207) does not work well.	Wash it with benzine and put one drop of glove oil on the axis with an oiler.
	7. Ankle of Slow speed escapement (207) does not bite the axis of Gear base (182).	Referring to 2-1 of SECTION II, adjust it.
8. Shutter drive ring (220) does not work well.	Adjust the balance of Shutter drive ring.	
9. The pin of Shutter drive ring (220) is bent, hitting Selftimer lever.	Bend the pin at right angles.	

TROUBLE	CAUSE	REPAIR
<p>Shutter blades do not close.</p>	<ol style="list-style-type: none"> 1. Slow speed escapement (207) does not work well. 2. Cocking & drive lever (206) does not slide Bulb lever (201) smoothly. 3. Bulb lever (201) does not slide the pin of Release bar (194) smoothly. 4. Oil sticks to Shutter blade (219). 	<p>Refer to SHUTTER "Shutter cannot be released" of SECTION I.</p> <p>Polish the side of Cocking & drive lever with oil stone and put MOS2 grease on it.</p> <p>Polish the side of Bulb lever and put MOS2 grease on it.</p> <p>Take out Shutter case (211) and wash Shutter blade with benzine, and also clean the oil stuck to Mount base assembly (197), Diaphragm covering disc (217), and Shutter case (211).</p>
<p><u>DIAPHRAGM</u> Diaphragm blades do not work well.</p>	<ol style="list-style-type: none"> 1. The pin of Diaphragm blade (216) is off. 2. Oil sticks to Diaphragm blade. 3. Set screw of Diaphragm drive ring (224) is loose. 4. Diaphragm drive ring is deformed. 	<p>Take out Shutter case (211), Diaphragm covering disc (217), and Diaphragm disc (214) and replace Diaphragm blade.</p> <p>Wash Diaphragm blade with benzine and clean the oil stuck to Shutter case (211), Diaphragm covering disc (217), and Diaphragm disc (214).</p> <p>Tighten it and put locking paint (synthetic resin) on it.</p> <p>Adjust the balance of it.</p>
<p><u>SELFTIMER</u> Selftimer does not operate.</p>	<ol style="list-style-type: none"> 1. Selftimer gear (180) does not come off the lever of Gear base (182). 2. Selftimer gear (180) does not work well. 3. Ankle holding spring hits Selftimer spring (181). 	<p>Referring to 3-1 of SECTION II, adjust it.</p> <p>Same as above</p> <p>Same as above</p>
<p><u>SYNCHRONIZATION</u> Flash does not fire.</p> <p>Flash does not synchronize.</p> <p>Flash blows out.</p>	<ol style="list-style-type: none"> 1. Lead wire is off, or M or X contact does not work well. 1. Contact time of X,M contact gets out of order. 1. Cover of lead wire peels off and insulation becomes ineffective. 2. Synchro-plug does not insulate. 3. X,M contact do not insulate. 	<ol style="list-style-type: none"> i. Solder the lead wire. ii. Clean X,M contact with benzine. iii. If X,M contact gets corrosive, replace it. <p>Refer to 6 of SECTION II.</p> <p>Replace the lead wire.</p> <p>Clean the plug or replace the plug and Insulation washer.</p> <p>When X,M contact touches the other part, refer to 6 of SECTION II, or replace Insulation washer.</p>

TROUBLE	CAUSE	REPAIR
<u>METER</u>		
Meter needle jumps.	<ol style="list-style-type: none"> 1. Resistance inside ASA ring (164) gets dirty or its carbon strip is uneven. 2. Fixed brush w/insulator (160) or Moving brush (170) is deformed, so that it does not contact ASA ring (164) well. 3. Connector (178) does not contact Connector ring (133) completely. 	<ol style="list-style-type: none"> i. Clean dirty spots with dry cloth. ii. If the carbon strip wears out, replace Resistance. <p>Adjust the figure of Fixed brush w/insulator or Moving brush so that its spring tension against ASA ring may be strong enough.</p> <p>Clean them and let them contact each other properly.</p>
Meter needle sticks.	<ol style="list-style-type: none"> 1. Meter needle and Stopper (Insulator) get dirty. 2. Pivot is too tight or loose. 	<p>Clean Meter needle and Stopper with thinner or change the position where Stopper touches.</p> <p>Adjust looseness to be 0.04 ± 0.01.</p> <p>Note: Tighten the pivot and the moment before Meter needle stops it should be regarded as looseness being zero and loosen the pivot 60°. This is a proper looseness.</p>
Meter needle is bent.	<ol style="list-style-type: none"> 1. Red celluloid needle is bent owing to temperature or humidity. 	<p>Replace it with the present Meter which has phosphor bronze needle.</p>
Meter needle stops.	<ol style="list-style-type: none"> 1. Wire is cut inside Meter. 2. Fixed brush w/insulator (160) contacts ASA ring. 3. Connector ring (133) does not contact Connector (178). 4. The soldered part of Lead wire is off. 	<p>Take out Meter and check the induction between Black lead wire and Meter cover by tester; when Meter shows ∞, replace Meter and in case of 0, pull out the wire as it short-circuits and put on vinyl tube for reuse.</p> <p>Correct the bend of Fixed brush w/insulator.</p> <p>Same adjustment as METER: "Meter needle jumps." of SECTION I</p> <p>Solder it again.</p>
Meter is out of balance.	<ol style="list-style-type: none"> 1. Balance of weight moves out or comes off. 2. Pivot is loose. 	<p>Replace it.</p> <p>Same adjustment as METER: "Meter needle jumps." of SECTION I</p>
<u>COUNTER</u>		
Counter does not advance.	<ol style="list-style-type: none"> 1. Advance pawl does not get in the first gear. 2. Momentum of advance pawl pin is small. 3. Advance pawl does not bite deep enough. 4. Counter ratchet spring (27) is off. 5. Counter pawl (24) does not bite deep enough. 	<p>Refer to 7 of SECTION II.</p> <p>Same as above</p> <p>Same as above</p> <p>Same as above</p> <p>Same as above</p>

TROUBLE	CAUSE	REPAIR
Counter does not return.	<ol style="list-style-type: none"> 1. Counter shaft pin does not work well. 2. Counter shaft pin touches Body cover. 3. Counter gear spring is off or coils round. 4. Counter pawl (24) bites too deep. 	<p>Refer to 7 of SECTION 11.</p> <p>Same as above</p> <p>Same as above</p> <p>Same as above</p>
<u>RANGE-FINDER</u>		
∞ is out of focus.	<ol style="list-style-type: none"> 1. Small mirror of Rangefinder frame (80) or Reflex mirror (93) is off. 2. Cam follower (85) does not work well. 3. The angle of Small mirror is wrong. 	<p>Clean the binding part and bind with mixed binding agent of Bond E2 and C1 (7:3).</p> <p>Take it out and clean it.</p> <p>Referring to 8 of SECTION II, adjust it by collimator.</p>
Near distance is out of focus.	<ol style="list-style-type: none"> 1. Same as above 	<p>Same as above</p>
Vertical discord of moving image	<ol style="list-style-type: none"> 1. Same as above 	<p>Same as above</p>

SECTION II : ADJUSTMENT

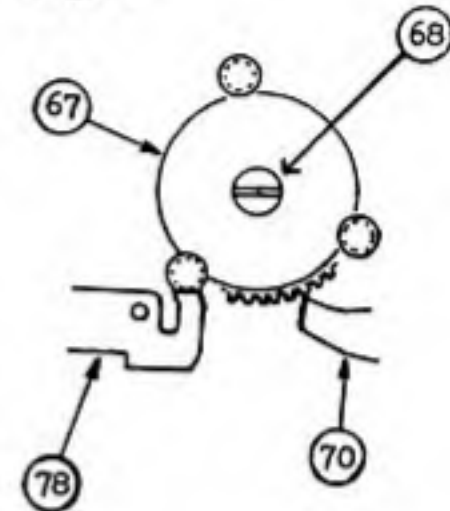
1. Adjustment of Amount of Winding and Wind gear pawl (70)

Note: Wind lever (57) while holding down Sprockets (41) with left hand thumb giving load not less than when film is loaded.

1-1. Adjustment of Wind gear pawl

The moment before Shutter set bar (78) is going to come off the pin of Shutter set and wind gear (67) adjust Eccentric washer (72) so that the tip of Wind gear pawl (70) may be placed at the teeth front of Shutter set and wind gear. (Fig. 1)

Fig. 1



When Shutter set bar came off Shutter set and wind gear and is 0.1 - 0.15 mm apart from Shutter set and wind gear shown in Fig. 2, the tip of Wind gear pawl gets in between the teeth of Shutter set and wind gear. (Fig. 3)

Fig. 2

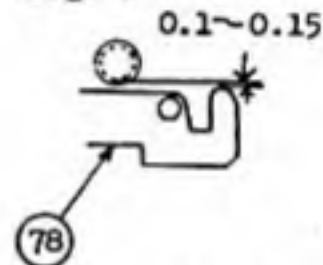


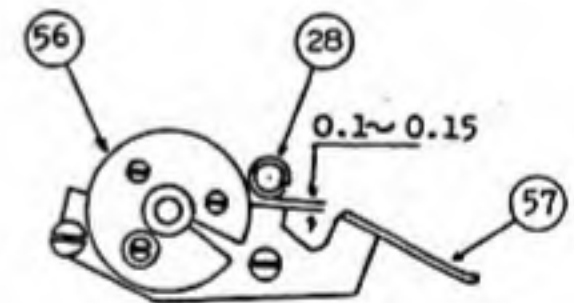
Fig. 3



Fig. 4

1-2. Adjustment of Amount of Winding

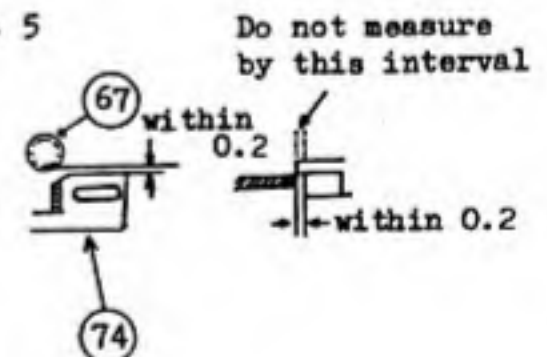
Wind lever should have further winding space of 0.1 - 0.15 mm from the position of Fig. 3. This adjustment is done by tightening Drive pin screw (54). Put locking paint (synthetic resin). (Fig. 4)



1-3. Checking of Stopper Position

When Wind lever is advanced fully, there should be a space not more than 0.2 mm between Stopper (74) and Shutter set and wind gear (67) but they should not touch each other. (Fig. 5)

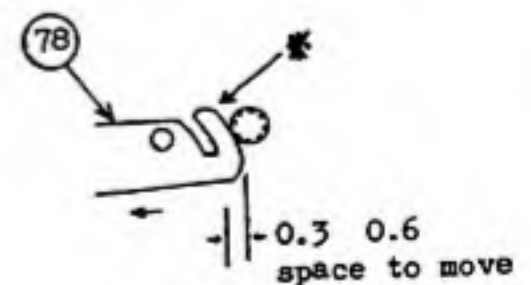
Fig. 5



1-4. Adjustment of Surplus amount of Winding of Cocking lever (226)

Advance Wind lever to set the shutter (not pressing Shutter button), disconnect Stopper (74) with finger, move Shutter set bar (78) as far as Set ring touches Cocking lever, then wind Wind lever so that Shutter set bar further may move 0.3 - 0.6 mm. This adjustment should be done by bending * part of Shutter set bar. (Fig. 6)

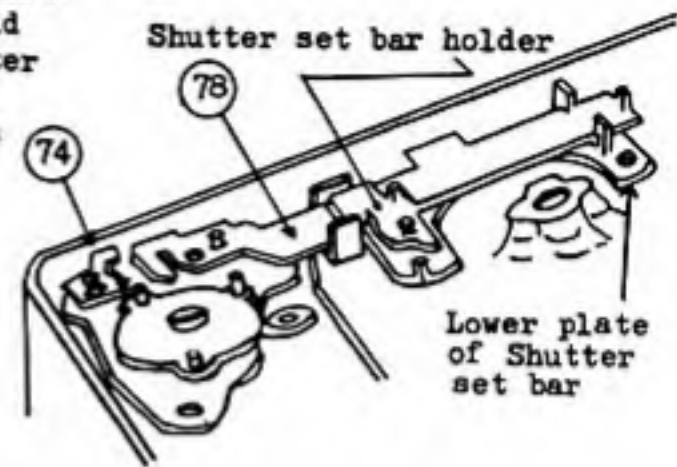
Fig. 6



1-5. Adjustment of Shutter set bar (78)

Adjust Shutter set bar holder so that Shutter set bar may not move by its weight when slanting the camera body but should move smoothly when Shutter set bar spring (76) hooks Shutter set bar. Vertical play should be held to a minimum. Put MOS2 grease on the sliding part of Shutter set bar and its holder. (Fig. 7)

Fig. 7



2. Adjustment of Slow speed escapement (207)
Adjustment of One second and Clutch

- 2-1. Adjust the pin of Shutter drive ring (220) so that it may make a right angle with Shutter drive ring.
- 2-2. Insert Shutter speed cam (165) and check that there should be no space between Ankle base post and Shutter speed cam. (Fig. 8)
- 2-3. Adjust the pin of Shutter drive ring and the foot of Escapement gear base so that there may be no play of Escapement ankle. (Fig. 9)
- 2-4. Upon checking the biting of Escapement ankle adjust the speed of one second.
- 2-5. Check that Clutch pin does not touch Shutter speed cam at 1/125 sec.
- 2-6. Check the movement of Slow speed escapement (207).

Fig. 8

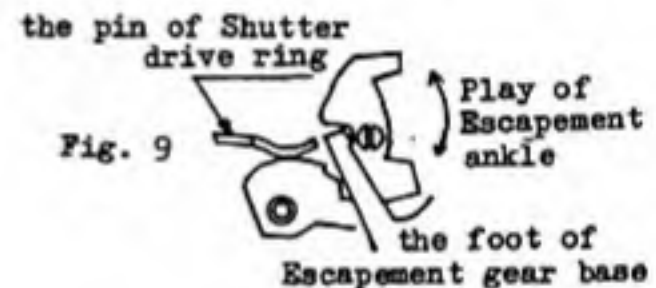


Fig. 9

3. Adjustment of Selftimer gear (180)

- 3-1. Check that Selftimer does not start because of the shock caused by Pendulum stopper hitting Selftimer spring (181) when Selftimer lever is set.
- 3-2. Before Selftimer lever is set give 0.6 mm space between Pendulum stopper and Selftimer spring. (Fig. 10)
- 3-3. Check the space between the pin of Shutter drive ring (220) and Sector gear of Selftimer (180).
- 3-4. Selftimer lever should be set at any given place within the operative range of 0° - 70° .
- 3-5. When Selftimer lever is set fully (70°), the operating time should be 7 to 11 sec.
- 3-6. Time when Selftimer is released is the same as MX fly wheel (184) starts or the former is released a little. This adjustment should be made by bending the hook of Selftimer. (Fig. 11)

Fig. 10

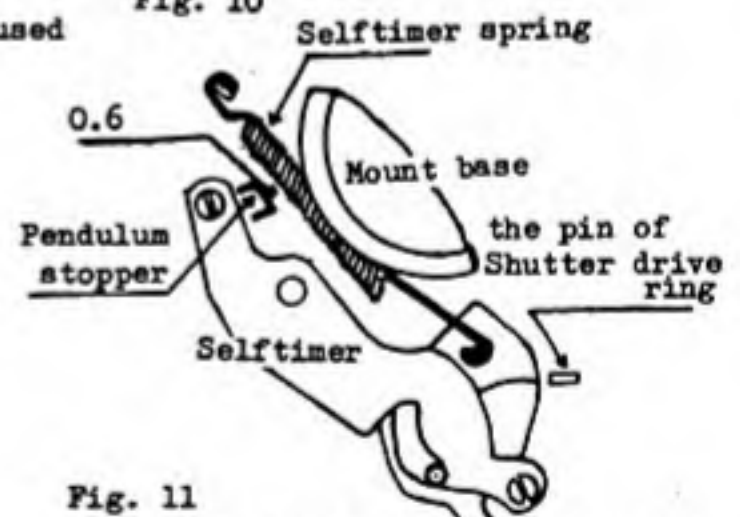


Fig. 11



4. Adjustment of Shutter speed

- 4-1. Measure the shutter speed always with aperture being fully open.
- 4-2. Pay special attention to the speeds of 1/8 and 1/125 sec. if they are irregular or not.
- 4-3. When the speed is slow, strike Shutter speed cam (165) with punch; when the speed is fast, scrape it with file.

Note: Clean the metal chips and scraps of Shutter speed cam to prevent them from getting inside.

5. Adjustment of MX delay action gear (185) and MX fly wheel (184)

- 5-1. Put glove oil around the axis of Gear base (182).
- 5-2. Insert MX fly wheel (184) into the axis of Gear base (182). Pull Release bar (194) and set the angle of Release bar at the cam of MX fly wheel. (Fig. 12)
- 5-3. Insert MX delay action gear (185) into the axis of Gear base (182). Fix so that the cut part of MX delay action gear may be on the straight line with the angle of Gear base. (Fig. 13)

5-4. Check the operation of MX fly wheel (184) and MX delay action gear (185)

- 5-4-1. When Cocking lever (226) is set, the extended line of the cut part of MX delay action gear should coincide with the center line of Sector gear teeth (189). (Fig. 14)

- 5-4-2. Actuate Cocking lever (226) slowly and the moment that Sector pawl gear (189) comes off Cocking & drive gear (206), the position of cam of MX fly wheel (184) should be 30° - 120° against Fly wheel stopper (193). (Fig. 15)

6. Adjustment of Synchronization Contact

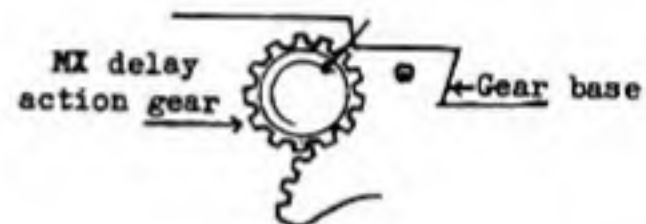
6-1. Adjustment of X contact

- 6-1-1. Adjust the figure of X contact so that X contact may not come off the pin of Shutter drive ring (220). (Fig. 16)

Fig. 12 Pull Release bar in the direction of the arrow mark.



Fig. 13

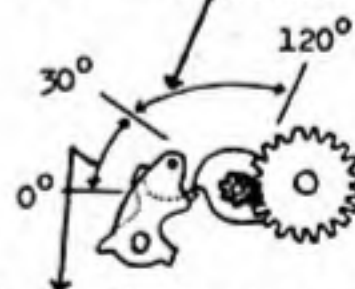


The position of the cut part of MX delay action gear when Cocking lever is set.

Fig. 14

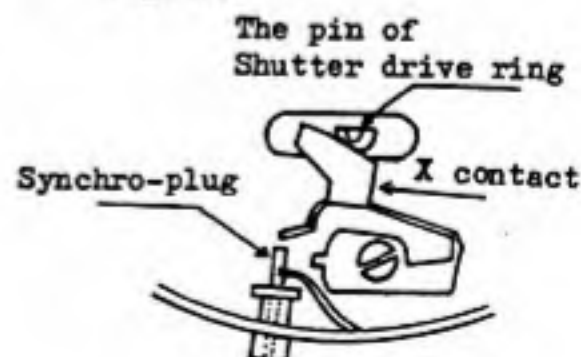


Fig. 15 The angle allowed to return



The improper range of angle to return

Fig. 16

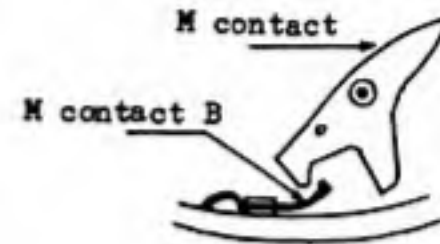


- 6-1-2. The moment before Shutter blade (219) is going to be fully open, the plug should contact X contact.
- 6-1-3. Check the insulation of X contact, Synchro-plug and Lead wire.

6-2. Adjustment of M contact

- 6-2-1. Bend M contact B toward M contact for better contact efficiency. (Fig. 17)
- 6-2-2. Check that M contact does not touch M contact B when the shutter is set with MX switch ring (223) set at M.
- 6-2-3. Check the insulation of M contact, M contact B and Lead wire.
- 6-2-4. Adjust time lag of synchro contact.
 - 6-2-4-1. Proper time lag is 13.0 to 16.0 ms.
 - 6-2-4-2. When time lag is fast, bring M contact B near M contact.
 - 6-2-4-3. When time lag is slow, keep M contact B away from M contact.

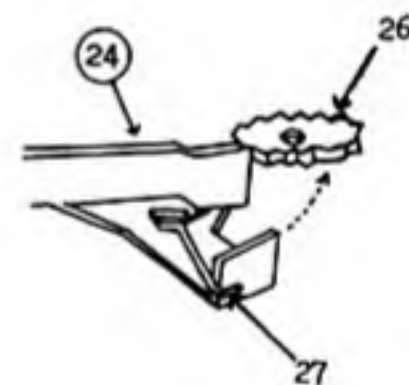
Fig. 17



7. Adjustment of Counter

- 7-1. When Back cover (111) is open, Counter pawl (24) should be 0.2 mm apart from the teeth edge of Counter gear (26).
- 7-2. Return Counter gear (26) to 0 and when Back cover is closed, the tip of Counter pawl (24) should get in the bottom of the third tooth of Counter gear. This should be done by adjusting Counter pawl. (Fig. 18)
- 7-3. When Wind lever is advanced, check that Advance pawl (27) gets in the bottom of the first tooth of Counter gear (26) advancing one tooth and leaving a space for Counter pawl (24) to get in the next tooth. This adjustment should be done by the eccentric screw of Wind lever.

Fig. 18



8. Adjustment of Range-finder

8-1. Adjustment of out-of-focus image

Set Focusing scale (135) at ∞ and view the chart in collimator or a subject more than 200 meters (660 ft.) away. If the subject (chart) is seen double as shown in Fig. 20, bend the front mirror frame till the images become one. (Fig. 19) (Fig. 21)

Fig. 19

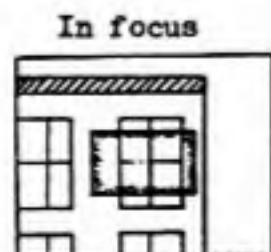


Fig. 20

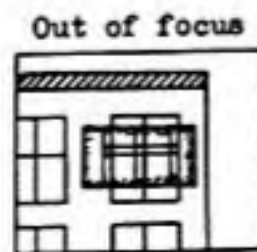
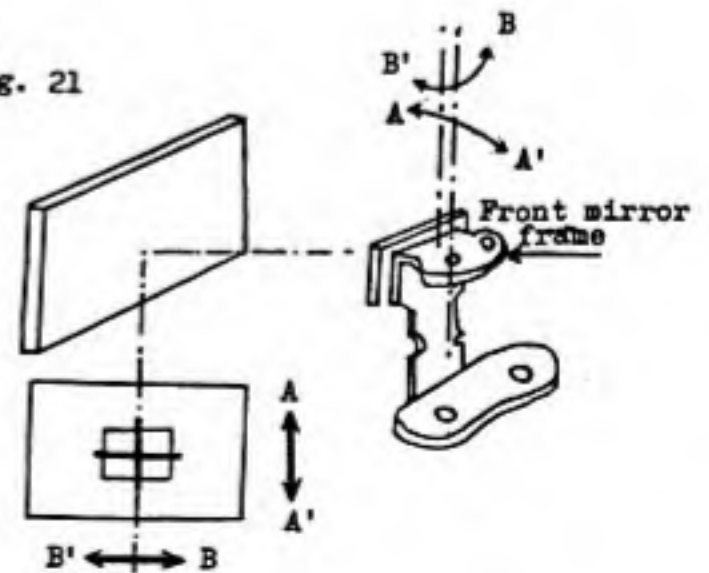


Fig. 21



8-2. Adjustment of focus at near distance

Set Focusing scale (135) at ∞ , place a focusing glass on the film plane of Body (110), loosen Helical stopper screws and adjust till a clear image is obtained. Next, focus a subject about 3 meters (10 ft.) away, in that condition view the subject on the film plane and the image should be clear then.

SECTION III : FINAL INSPECTION

Repairs and assembly being finished, the final inspection follows. Such a strict inspection as done in the manufacturing process is not necessary. Hereunder are the points necessary for the final inspection.

1. Wind Lever

Wind lever must operate from start to finish, smoothly without feeling rough, stuck or sticky. When Wind lever is returned slowly, it should return to the original position prior to winding.

2. Film Counter

Open Back cover to return Film counter to '0', looking at Film counter wind Wind lever and check if the graduation of Counter dial advances one by one. Next, check if the graduation regularly advances regardless of whether Wind lever is returned slowly or rapidly. When the graduation advances regularly to a finish, open Back cover slowly to see if Film counter returns to "S" completely.

3. Shutter Button

Shutter button should operate smoothly when it is being pressed down and should come back up smoothly when it is let go.

4. Rewind knob should rotate smoothly without getting stuck.

5. When Rewind button is pressed, Sprockets should rotate smoothly.

6. Rotate Film spool with finger-tip to check that there is appropriate weight and no unevenness.

7. Rotate Helicoid to check that there is no roughness and unevenness.

8. Rotate Diaphragm ring to check that there is no roughness and unevenness and Diaphragm blades move properly.

9. Rotate Shutter speed cam to check if it click-stops correctly.

10. Shutter Speed

Measure the exposure time at 1/500, 1/15, and 1/1 sec.
Set Selftimer lever and release the shutter to check if it is coupled correctly.

11. Synchro Contact

Check the induction of X and M synchronization.

12. Meter Needle

Rotate Shutter speed cam and Diaphragm ring to check the movement of Meter needle. Next, measure LV in accordance with the following chart:-

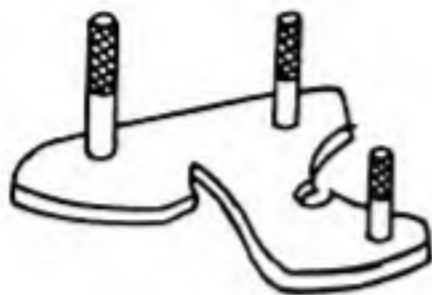
LV	9	12	15
Shutter	15	30	500
f	2.8	11	11
ASA	25	100	200

13. Focus and Finder

Check focus by means of collimator or by aiming at a subject over 200 meters (660 ft.) away. Check that there is no dirt or dust in the view-finder.

14. Check winding and rewinding with film loaded.

ATTACHMENT: TABLE OF PARTICULAR TOOLS



Cam follower (85) gauge

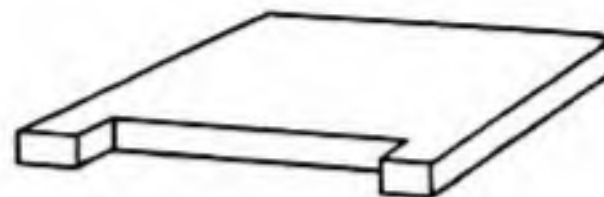
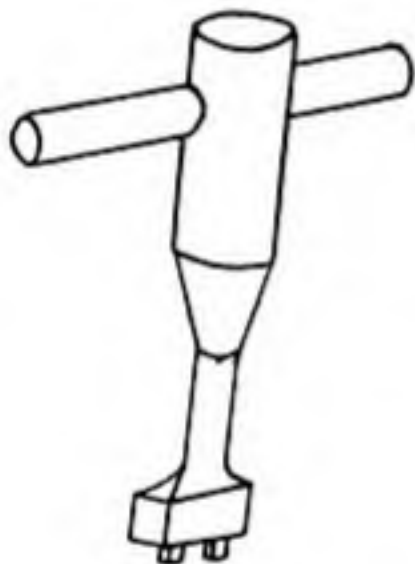


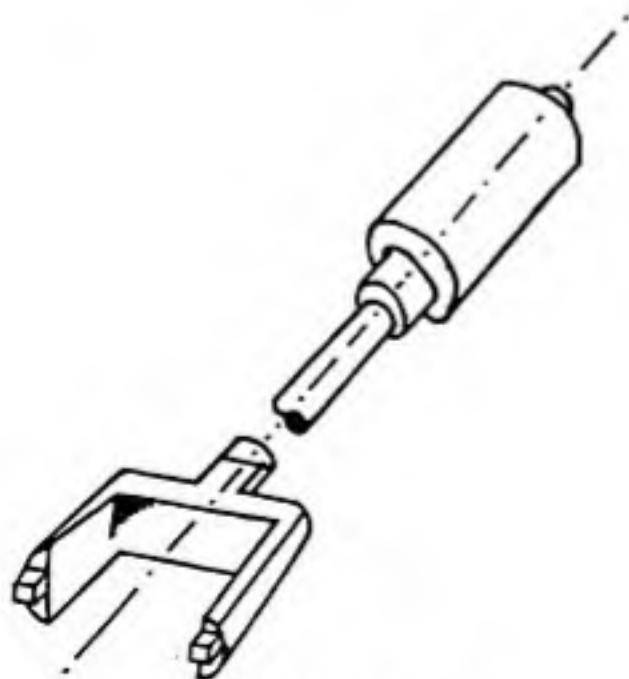
Photo-cell window retainer (155) driver



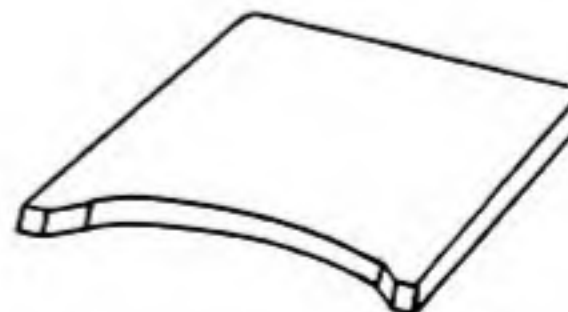
Focus Adjuster



Lens number ring (150) driver



Jam nut (147) driver



No.6 lens in spacer ring (176) driver

PETRI PARTS LIST

7 SEVEN S



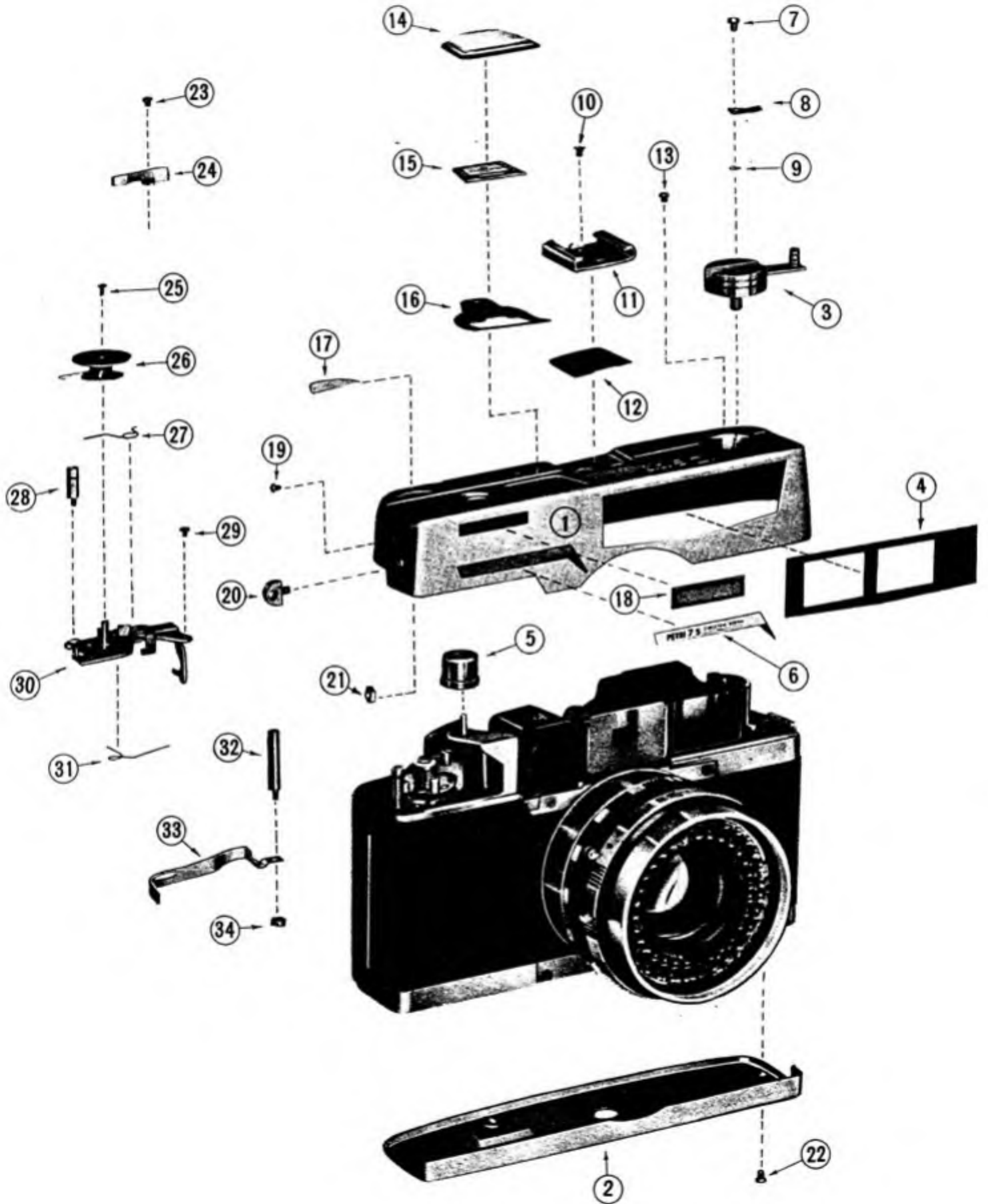


FIG.	PART NO.	DESCRIPTION	UNIT
1	L3P-1	Top cover (トップカバー)	1
2	L2P-2	Bottom cover assembly (底板一式)	1
3	SPB-108	Rewind knob assembly (捲戻しレバー一式)	1
4	L2P-26	Viewfinder front plate (ファインダーマスク)	1
5	L3B-11	Shutter release button (押釦)	1
6	L3P-40	Name plate (ネームプレート)	1
7	PDB-122	Friction spring screw (捲取レバーバネ取付)	1
8	SP-140	Friction spring (捲取レバーバネ)	1
9	SP-141	Friction spring spacer (捲取レバーバネ座金)	1
10	BPR-19	Accessory shoe screw (差込座取付)	2
11	L2P-25	Accessory shoe (差込座)	1
12	L3P-51	Light baffle paper (差込座遮光紙)	1
13	BPR-17	Rewinder-side top cover screw (カバー取付 'A')	2
14	L3P-30	Needle window (指針窓)	1
15	L3P-33	Needle window plate (指針ネーム板)	1
16	L3P-34	Back-up spring (指針ネーム支持バネ)	1
17	L3P-43	Counter window (指数窓)	1
18	L3P-42	Decorative nylon filling (カバー窓板)	1
19	PR-18	Top cover screw (カバー取付 'B')	1
20	NPM-1003	Strap loop (吊環)	2
21	NPM-1004	Strap loop nut (吊環ナット)	2
22	PM-19	Bottom cover screw (底板取付)	2
23	PDB-123	Counter pawl screw (止め爪取付)	1
24	L3P-29	Counter pawl (止め爪)	1
25	PHB-32	Counter dial screw (カウンターダイヤル取付)	1
26	L3P-27	Counter dial assembly (カウンターダイヤル一式)	1
27	L3W-9	Counter ratchet spring (送り爪スプリング)	1
28	L3B-17	Spring retaining post (カバー台)	1
29	SPB-146	Counter base screw (カウンターベース取付)	1
30	L3P-25	Counter base assembly (カウンターベース一式)	1
31	E2W-5	Counter reset bar spring (カウンターバースプリング)	1
32	L3B-34	Slot cover screw (レバーカバー取付)	1
33	E2P-3	Slot cover (捲取レバーカバー)	1
34	L3B-31	Slot cover spacer (捲取レバーカバー座金)	1

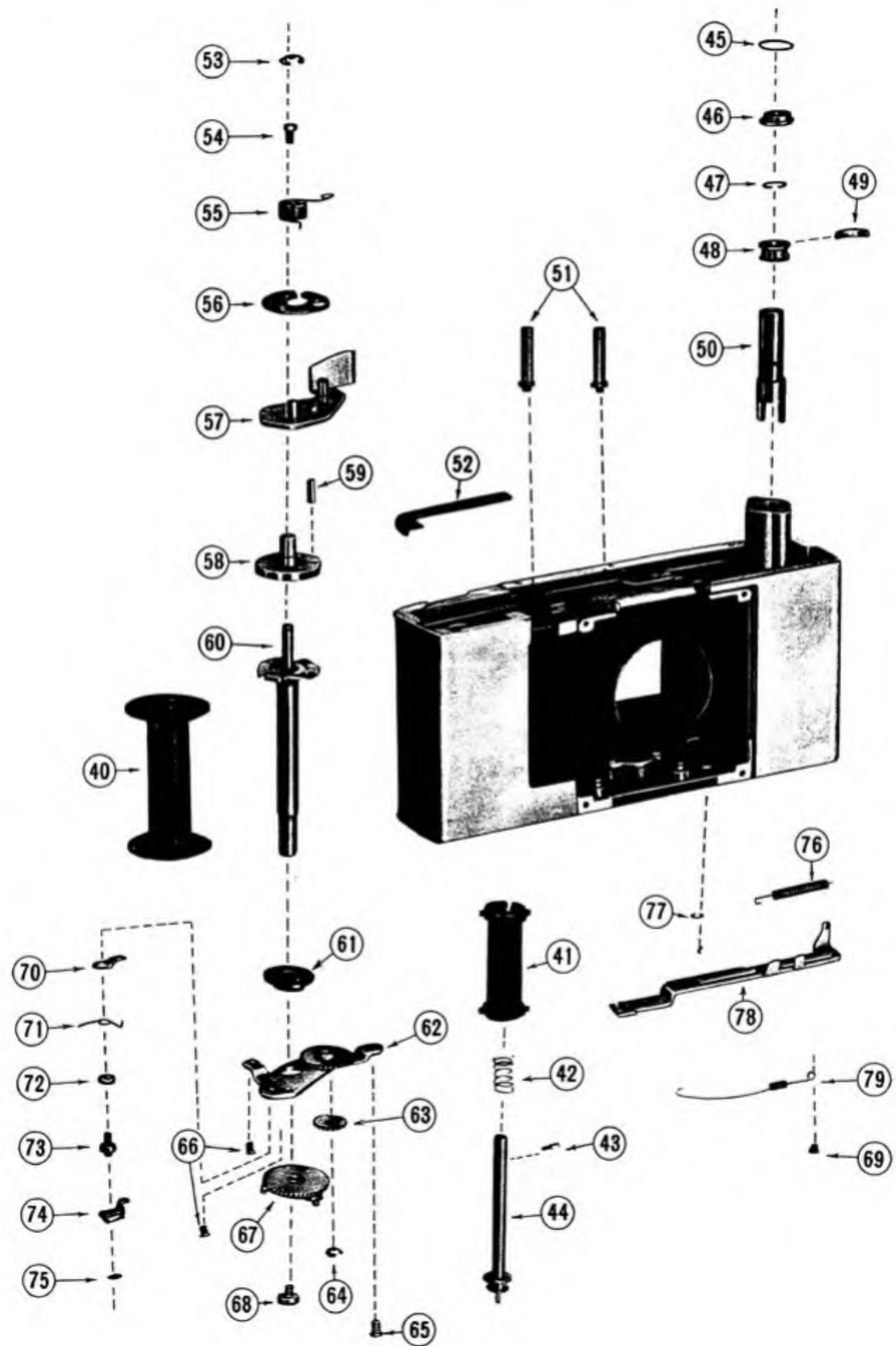


FIG.	PART NO.	DESCRIPTION	UNIT
40	PM-17	Film spool assembly (リール筒一式)	1
41	EB-61	Sprockets (スプロケット)	1
42	PW-4	Tension spring (スプロケットバネ)	1
43	EB-5	Drive pin (スプロケットノック)	1
44	L3B-25	Drive shaft assembly (スプロケット芯棒一式)	1
45	NO-37	Washer (座金)	1
46	L2B-15	Upper spool bearing (捲戻芯棒軸受)	1
47	L2W-2	Spool bearing retainer (捲戻芯棒カラー押え)	1
48	L2B-14	Spool bearing (捲戻芯棒カラー)	1
49	L2P-27	Spool friction spring (捲戻芯棒カラー スプリング)	1
50	L2B-13	Rewind shaft (捲戻芯棒)	1
51	L3B-8	Wind lever stopper (捲取レバーストッパー)	2
52	E2P-4	Slot cover base (捲取下カバー)	1
53	E-2.3	E-Ring (捲取筒用スナップリング)	1
54	L3B-54	Drive pin screw (捲取レバー取付)	3
55	L3W-1	Lever return spring (捲取レバースプリング)	1
56	L3P-13	Drive pin spring (捲取ノックバネ)	1
57	E2P-1	Wind lever assembly (捲取レバー一式)	1
58	L3B-1	Wind lever base (捲取筒)	1
59	L3B-2	Drive pin (捲取ノック)	1
60	L3B-4	Wind shaft assembly (捲取芯棒一式)	1
61	L3P-21	Spool clutch assembly (リール筒爪一式)	1
62	L3P-8	Gear plate assembly (ギヤプレート一式)	1
63	L3P-10	Intermediate gear (捲取中間ギヤ)	1
64	E-1.9	E-Ring (中間ギヤ用スナップリング)	1
65	L3B-15	Gear plate screw 'long' (ギヤプレート取付 '大')	1
66	SPB-146	Gear plate screw 'short' (ギヤプレート取付 '小')	2
67	L3P-6	Shutter set and wind gear (捲取ギヤ一式)	1
68	L3B-6	Screw for L3P-6(counter clock-wise)(捲取ギヤ取付)	1
69	BPR-8	Stopper spring screw (ストッパースプリング取付)	1
70	L3P-19	Wind gear pawl (逆転止)	1
71	L3W-4	Pawl spring (逆転止スプリング)	1
72	L3B-16	Eccentric washer (逆転止エキセン)	1
73	L3B-55	Pawl screw (逆転止取付)	1
74	L3P-50	Stopper (シャッターチャージ桿ストッパー)	1
75	E-1.5	E-Ring (スナップリング)	1
76	L3W-6	Shutter set bar spring (シャッターチャージ桿スプリング)	1
77	E-1.5	E-Ring (スナップリング)	2
78	L3P-14	Shutter set bar (シャッターチャージ桿)	1
79	L4W-2	Stopper spring (チャージ桿ストッパースプリング)	1

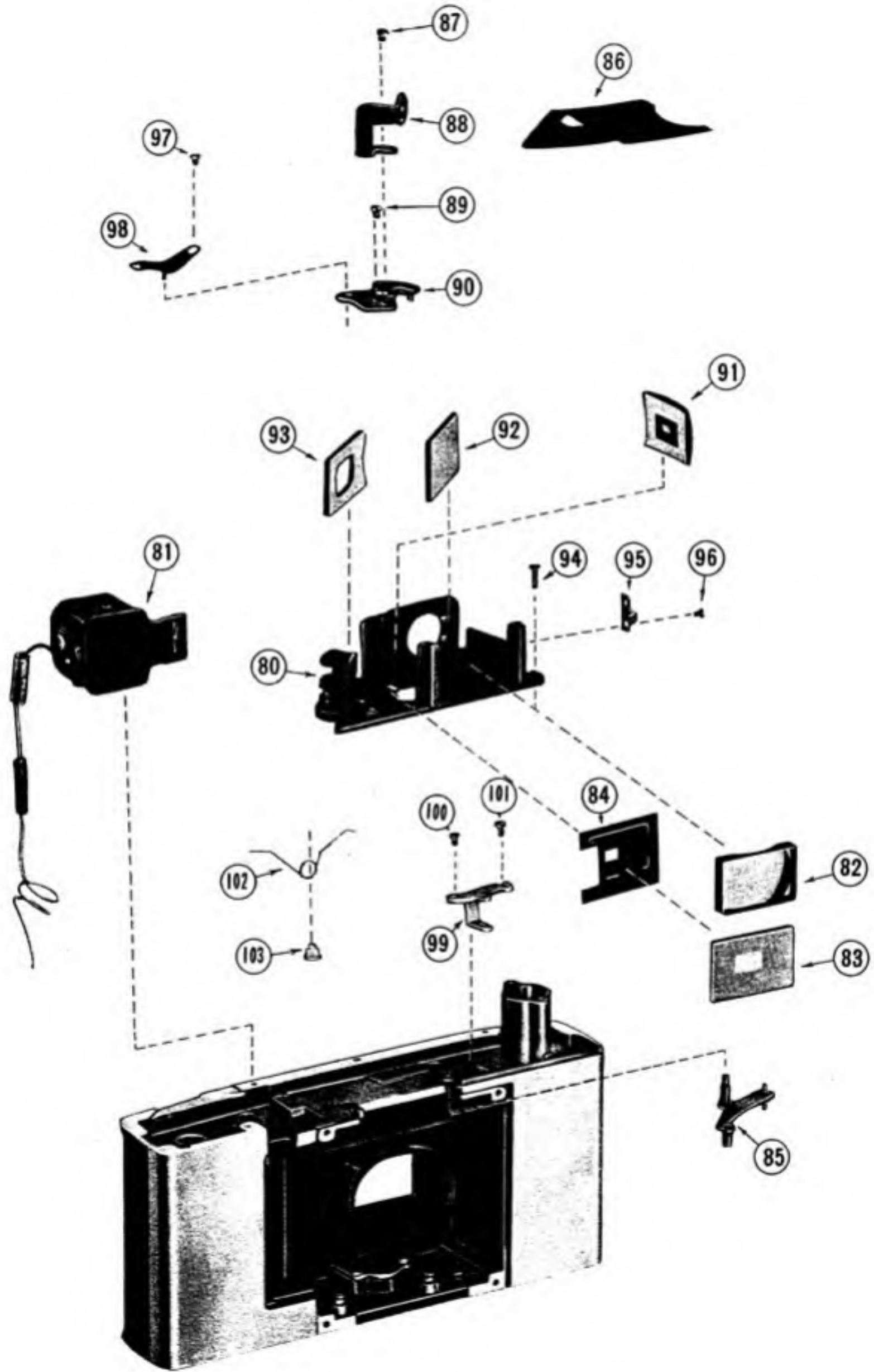


FIG.	PART NO.	DESCRIPTION	UNIT
80	L2DC-2	Rangefinder frame w/small mirror (地板)	1
81	L3P-36	Exposure meter (メーター)	1
82	L2L-1	Front field lens (対物レンズ)	1
83	L2L-7	Green ground glass (グリーンガラス)	1
84	L2P-24	Bright frame mask (チャート枠)	1
85	L2P-17	Cam follower (連動桿一式)	1
86	LP-26	Light baffle (距離計蓋)	1
87	PR-8	Negative lens screw (移動レンズ取付)	1
88	L2L-3	Negative lens assembly (移動レンズ一式)	1
89	PR-8	Negative lens bracket screw (調節板取付)	1
90	L2P-47	Negative lens bracket (調節板一式)	1
91	L2L-4	Large negative lens (中間レンズ)	1
92	L2L-5	Half mirror (半透明鏡)	1
93	L2L-6	Reflex mirror (チャート表面鏡)	1
94	BPM-43	Rangefinder frame screw (地板取付)	3
95	L2P-23	Mirror holder spring (半透明鏡押え)	1
96	PDB-123	Holder spring screw (半透明鏡押え取付)	2
97	PRB-123	Spring pivot screw (移動レンズ押え取付)	2
98	L2P-22	Spring pivot (移動レンズ押え)	1
99	L2P-18	Cam follower support (連動桿台)	1
100	BPU-6	Cam follower support screw (連動桿台取付 'A')	1
101	SPB-146	Adjuster screw (連動桿台取付 'B')	1
102	L2W-1	Cam follower spring (連動桿スプリング)	1
103	L2B-9	Screw for L2W-1 (連動桿スプリング掛)	1

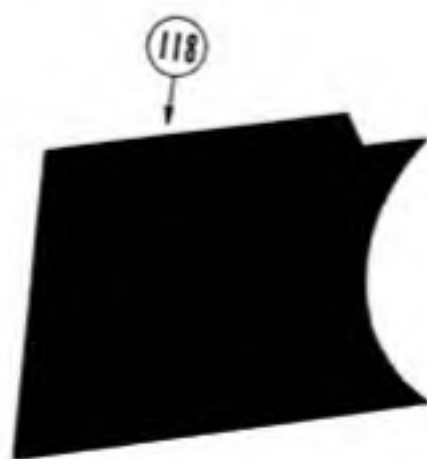
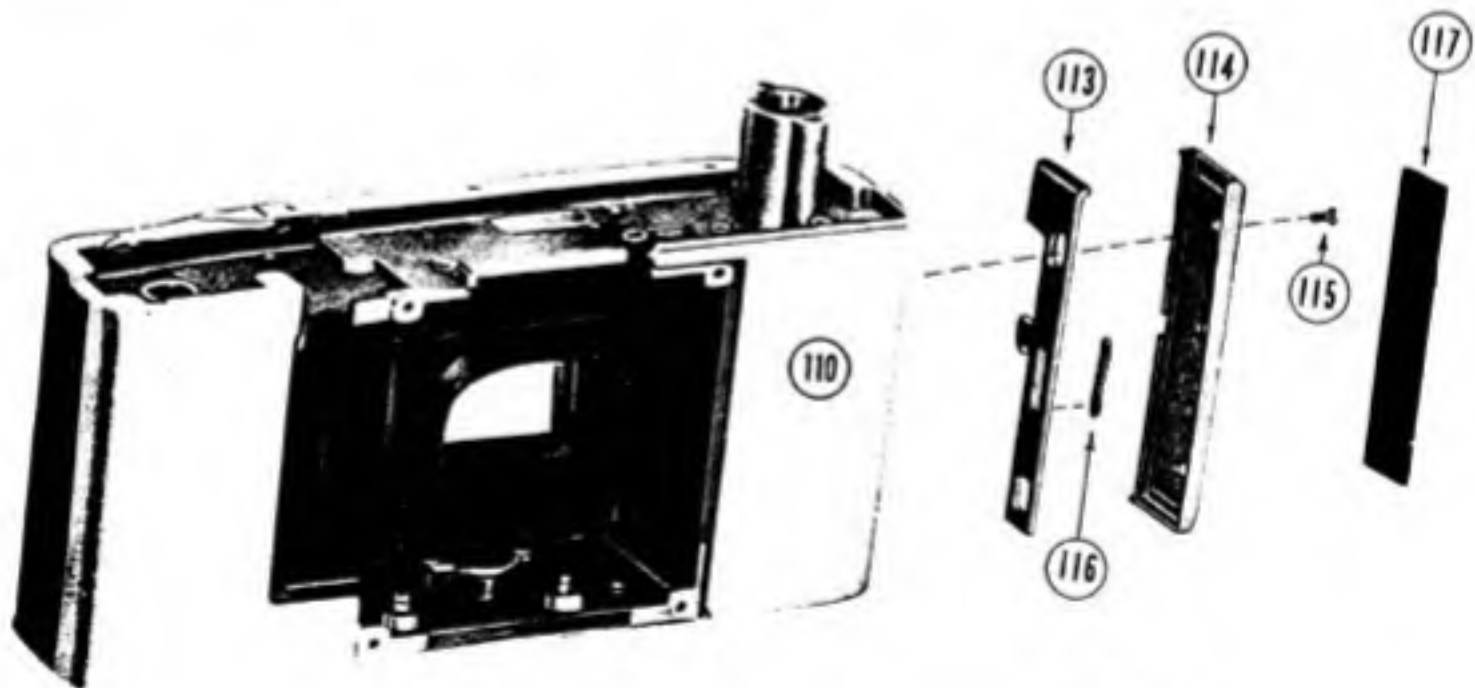
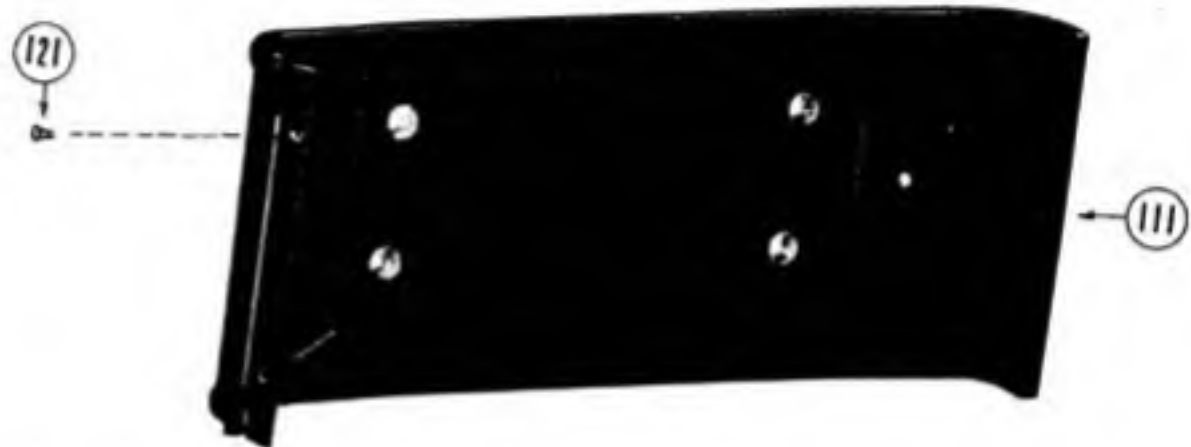


FIG.	PART NO.	DESCRIPTION	UNIT
110	L3DC-1	Body (ボディ)	1
111	L2-5	Back cover assembly (裏蓋一式)	1
112	PU-3	Pressure plate assembly (圧板一式)	1
113	L2P-4	Back cover latch (蓋止引出)	1
114	L2P-3	Latch cover (蓋止カバー)	1
115	PU-6	Latch cover screw (蓋止カバー取付)	2
116	PW-2	Latch spring (蓋止スプリング)	1
117	L2K-4	Leatherette-latch cover (蓋止皮)	1
118	L2K-1	Leatherette-front left (前皮一左)	1
119	L2K-2	Leatherette-front right (前皮一右)	1
120	L2K-3	Leatherette-back cover (後皮)	1
121	PU-1	Hinge screw (裏蓋一式取付)	2

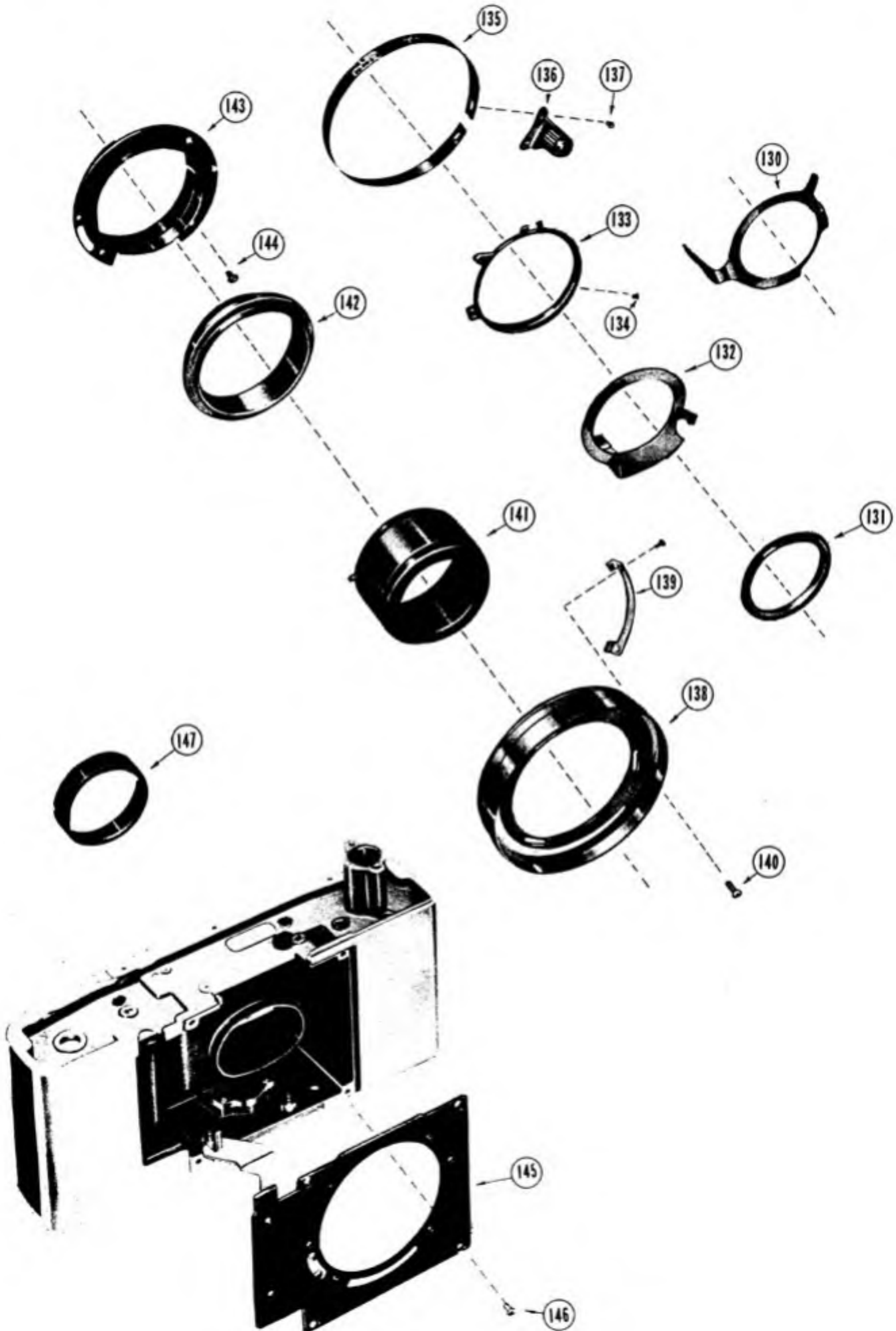


FIG.	PART NO.	DESCRIPTION	UNIT
130	L3P-17	Shutter release ring (シャッターレバー)	1
131	L2B-20	Spacer ring (座金)	1
132	L3P-12	Shutter set ring (シャッターセットリング)	1
133	L2P-40	Connector ring (接片台)	1
134	SPB-102	Connector ring screw (接片台取付)	2
135	L3P-41 (L3P-41B)	Focusing scale (距離目盛)	1
136	NPS-1003	Focusing knob assembly (焦点調節つまみ一式)	1
137	BPS-19	Focusing knob screw (焦点調節つまみ取付)	2
138	L3P-37	Cup (ヘリコイドスケール台一式)	1
139	L3P-44	Helical gear stopper (ヘリコイドストッパー)	1
140	PS-11	Cup screw (ヘリコイドスケール台取付)	3
141	LB-29	Helical drum assembly (ヘリコイド内筒一式)	1
142	NPS-1012	Helical ring (ヘリコイド中筒)	1
143	L2B-36	Mount ring assembly (ヘリコイド外筒一式)	1
144	BPS-19	Mount ring screw (ヘリコイド外筒取付)	4
145	L3P-13	Mount plate assembly (シャッター台一式)	1
146	BPS-17	Mount plate screw (シャッター台取付)	4
147	GLB-64	Jam nut (シャッター取付リング)	1
148	M-206	Stopper screw (ヘリコイドストッパー取付)	2

Note: Refer numbers in () for 7S f2.8 camera parts

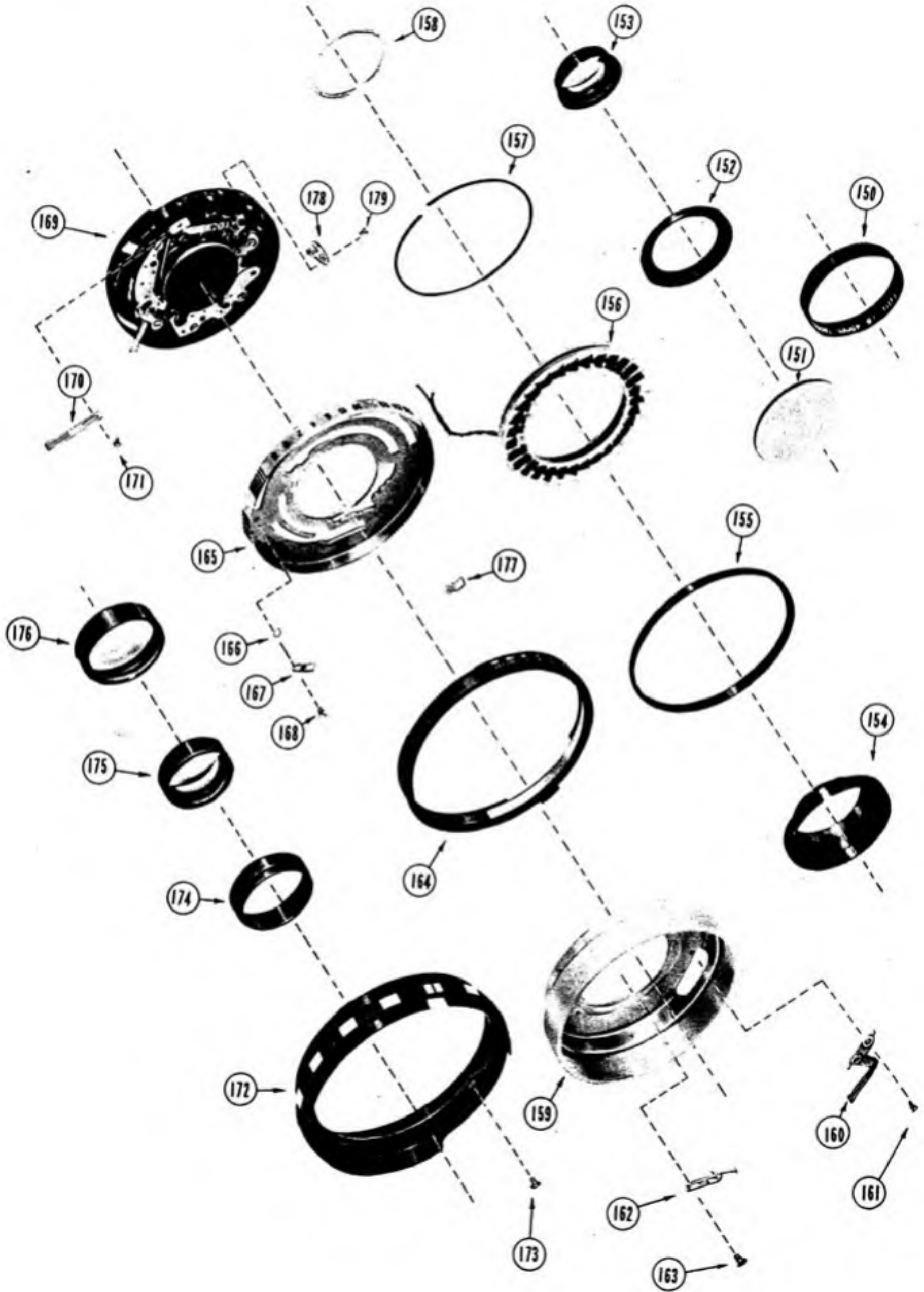


FIG.	PART NO.	DESCRIPTION	UNIT
150	L3B-50 (L3B-35)	Lens number ring (前枠)	1
151	NG-1 (AG-1)	No. 1 lens (front) (前玉)	1
152	L2B-56	No.2 & No.3 lens retainer (中枠座)	1
153	NG-2-3 (AG-2)	No.2 & No.3 cemented lens (中玉)	1
154	L2B-30 (L3B-36)	Front lens cell (中枠)	1
155	L2B-51	Photo-cell window retainer (光電池取付リング)	1
156	L3P-45	Photo-cell assembly (光電池)	1
157	L3B-52	Spacer (複眼レンズ台)	1
158	M-153	Shutter cam retainer (ネーム板取付)	1
159	VEP-251	Front assembly cup (ネーム板)	1
160	VEP-206	Fixed brush w/insulator (固定接片 'A')	1
161	VEB-7	Brush screw (固定接片取付)	2
162	VEP-8	Click spring (クリック板)	1
163	VEB-210	Click spring screw (クリック板取付)	2
164	VEB-231 (VEB-201)	ASA & DIN dial assembly (ASAリング)	1
165	VEP-233 (VEP-204)	Shutter speed cam (カム板)	1
166	0201-20	Washer (ワッシャー)	1
167	VEP-234	Supporter spring (ASAリング 押え 'B')	1
168	VEB-210	Supporter spring screw (ASAリング 押え取付)	2
169	MVB-204	Shutter & diaphragm assembly (シャッター一式)	1
170	VEP-209	Moving brush (移動接片)	1
171	VEB-8	Moving brush screw (移動接片取付)	1
172	VEB-251	Diaphragm control ring (絞り目盛環)	1
173	VEB-210	Fix screw (Diaphragm control ring) (絞り目盛環取付)	3
174	LB-5 (P3B-1)	Lens retainer (後枠)	1
175	NG-4-5 (AG-3-4)	No.4 & No.5 cemented lens (後玉)	1
176	NG-6 (P3B-2)	No.6 lens in spacer ring (後枠リング)	1
177	VEP-205	Supporter spring (ASAリング押え)	1
178	VEP-208	Connector (固定接片 'C')	1
179	VEB-7	Connector screw (固定接片取付)	2

Note: Refer numbers in () for 7S f2.8 camera parts.

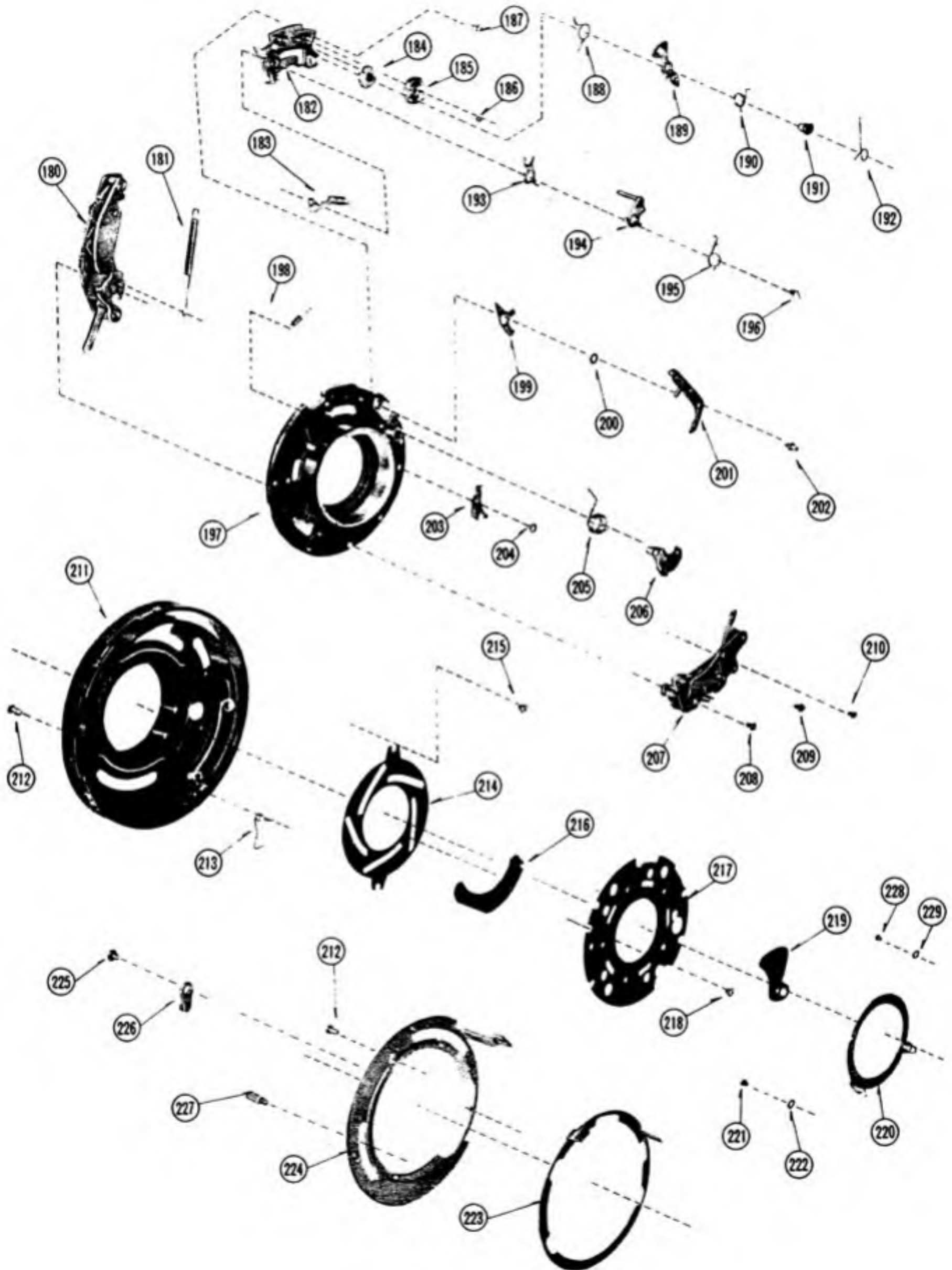


FIG.	PART NO.	DESCRIPTION	UNIT
180	VEB-261-6	Selftimer gear assembly (セルフタイマー一式)	1
181	PW-41	Selftimer spring (セルフタイマーสปリング)	1
182	MV-1	Gear base (ハンドル台)	1
183	MV-8	Drive ring stopper (開閉板止め)	1
184	MV-11	MX Fly wheel (MCギヤー)	1
185	MVB-133	MX delay action gear (MBギヤー)	1
186	PW-61	Gear spring washer (Mギヤースプリングワッシャー)	1
187	MV-120	Gear base screw (ハンドル台取付)	2
188	PW-67	Drive ring stopper spring (開閉板止めスプリング)	1
189	MV-10	Sector gear (M扇形ギヤー)	1
190	PW-64	Sector gear spring (M扇形スプリング)	1
191	VEB-105	Sector gear screw (扇形取付)	1
192	PW-62	Bulb lever spring (バルブスプリング)	1
193	MV-9	Fly wheel stopper (Mギヤー止め)	1
194	MV-6	Release bar (レバーハンドル)	1
195	PW-63	Release bar spring (レバーハンドルスプリング)	1
196	MVB-106	Release bar screw (ハンドルめネジ)	1
197	MVB-204	Mount base assembly (中板)	1
198	PW-70	Fly wheel stopper spring (Mギヤー止めスプリング)	1
199	MV-14	M contact (M接点)	1
200	MV-15	M contact washer (M接点 Bワッシャー)	1
201	MV-7	Bulb lever (バルブ)	1
202	VEB-203	Bulb lever screw (バルブめネジ)	1
203	MP-11	X contact (X接点)	1
204	M-108	X contact screw (X接点取付)	1
205	PW-68	Cocking lever spring (Sレバーสปリング)	1
206	MV-3	Cocking & drive lever (Sレバー)	1
207	MV-16-26	Slow speed escapement (秒ギヤー)	1
208	MVB-137	Escapement screw A (秒ギヤー取付 'A')	1
209	M-114	Escapement screw B (秒ギヤー取付 'B')	1
210	VEB-215	Escapement screw C (秒ギヤー取付 'C')	1
211	VEB-405	Shutter case (シャッターケース)	1
212	M-111	Shutter case screw (中身取付 'A')	3
213	PW-73	MX switch ring spring (切換クリックバネ)	1
214	VEP-2	Diaphragm disc (絞り押え 'B')	1
215	VEB-209	Diaphragm disc screw (絞り押え 'B' 取付)	2
216	VEP-3	Diaphragm blade (絞り羽根)	5
217	VEP-1	Diaphragm covering disc (絞り押え 'A')	1
218	M-117	Diaphragm covering disc screw (絞り押え取付)	1
219	MV-37	Shutter blade (五枚羽根)	5
220	MV-2	Shutter drive ring (開閉板)	1
221	M-107	Shutter blade screw (開き押え取付)	4
222	MP-3	Shutter blade screw washer (開閉板押え)	4
223	VEP-252	MX switch ring (切換レバー)	1
224	VEP-231	Diaphragm drive ring (絞りリング)	1
225	M-206	Cocking lever screw (Sレバー 'C' 取付)	1
226	MP-36	Cocking lever (Sレバー 'C')	1
227	VEB-208	Diaphragm drive ring stopper (中身取付)	1
228	VEB-141	Shutter blade screw (開き押え取付)	1
229	MV-44	Shutter blade screw washer (開閉板押え 'A')	1